



**Installation**  
**Operation**  
**Maintenance**  
**Troubleshooting**

Version 1.1, Oct/10



**Biscayne E.L. Dental Light**

# INDEX

---

Dear Customer	3
Product Description	3
General Data	4
Technical Specifications	4
Special Care or Particular Conditions for Installation	5
Transportation and Storage Conditions	5
Products Symbols	5
Packing Symbols	5
Dimensions	6
Operation	7
Activating the Light	7
Head Movement	7
Maintenance	7
Recommendations for the Conservation of Dental Equipment	7
Changing the Bulb	8
Cleaning the Splash Shield	8
Cleaning the Equipment	9
Troubleshooting	9
Installation	10
Warranty	17
Final Considerations	18

# DEAR CUSTOMER

---

Congratulations! All of us at Summit Dental Systems want you to know that your Biscayne E.L. Light has been built with the finest materials available. The assembly and testing was completed by technicians devoted to making Summit Dental Systems products perform to all prescribed specifications. Our five year limited warranty is just one of the ways we express our confidence that you will be completely satisfied with your purchase. We appreciate your support and look forward to meeting your future professional needs through our expanding product line.

This manual is a general presentation of your product and it will give you important details to help you solve possible problems. Please read this manual thoroughly and keep it for future reference.

## PRODUCT DESCRIPTION

---

This reflector was designed for dental use. Standard features include gradual intensity adjustment (from 14,000 to 20,000 Lux) through the dental chair's foot control, smooth movements, and in a standard light gray color that is compatible with all environments.

The head is made of a resistant material. It swivels 620° providing lightness, durability and wide mobility in all the positions. It comes with bilateral knobs that allow for isolation to avoid the risk of cross contamination. The multifaceted mirror is treated with multi-coating to generate numerous light sources and avoid shadows caused by interposition. The protector of the mirror is made with a sturdy transparent material to protect it from any sprays.

The steel arm provides vertical and horizontal movements and has rounded corners. It is coated with flat paint and is easily cleaned and sterilized. The high gloss paint is based on epoxy, cured in an oven at 482°F (250°C) with phosphate treatment making it resistant to corrosion and cleaning materials.

### IMPORTANT:

- This equipment is for professional use only. It must be operated and utilized by a specialized professional (certified professional, according to the legislation of the country) and following the instructions of the manual.
- It is the user's responsibility to only use instruments that are in perfect condition and to protect themselves, the patients, and others from dangerous situations.
- After the equipment has completed its life cycle, this equipment must be disposed of in an appropriate area (according to the legislation of the country).
- To guarantee the safe functioning of your equipment, use only the Summit Dental Systems assembly configurations (Dental Chair, Delivery Units, Assistant's Instrumentation, and Dental Light) supplied by Summit Dental Systems authorized Dealers/Technical Assistance.

# GENERAL DATA

## Equipment Maintenance

The unit requires no preventive maintenance, but in the occurrence of any problem that cannot be solved with the information in this manual, ask for the assistance of an authorized Summit Dental Systems technician.

## Parts Lists and Circuit Diagrams

Summit Dental Systems declares that the provision of circuit diagrams, parts list, or any other information that provide technical assistance to the user, may be requested, provided that it's previously agreed between the User and Summit Dental Systems.

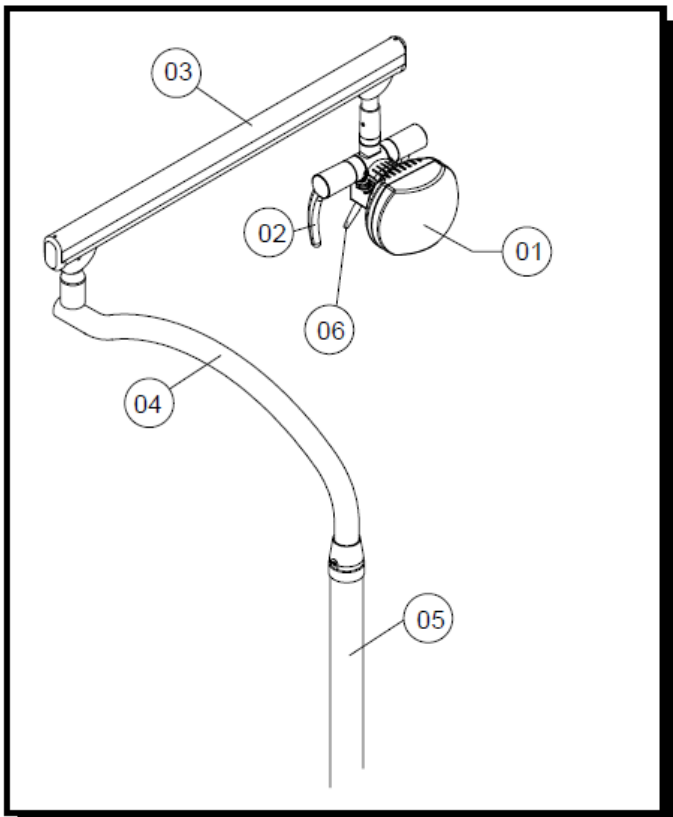

- 01) Shield
- 02) Handle
- 03) Articulated Arm
- 04) Rigid Arm
- 05) Column
- 06) On / Off Switch

## TECHNICAL SPECIFICATIONS

• **Power Supply**

11V DC~ and 12V DC~ from  
Dental Chair PCB

• **Net Weight**

6.5 Lbs (14.4 Kg)

• **Lamp**

H3 12V 55W

• **Brightness**

14,000 to 20,000 LUX

• **Gross weight**

8 Lbs (17.8 Kg)

• **Distance between the head  
and the operative field**

27.5in (70cm)

# TECHNICAL SPECIFICATIONS

## Special Care or Particular Conditions for Installation

- Check the electrical net, it must be compatible with the specified one in the equipment.
- Verify if the outlet is grounded; it must be turned off correctly.

**Note:** This information is also available in the Manual of Installation and Maintenance of the equipment that can be found with an authorized Summit Dental Systems technician.

## Transportation and Storage Conditions

The equipment must be transported and stored with the following observations:

- Fragile! Should not suffer drop or receive impact.
- With the arrows pointing upward.
- With humidity protection, not to be exposed to rain, water drops, or wet floor.
- With a maximum stacking of 12 units for storage.



## Product Symbols



Warning



Ground (in various parts of equipment) indicates the condition of being grounded

## Packing Symbols



The equipment must be protected from exposure to direct sun light during storage and transportation.



Equipment not get wet, rained on, or placed on a wet floor during transportation or storage.



Package to be transported and stored with the arrows up.



Temperature limit for storing and transportation of package



Maximum stacking determines the maximum number of boxes which can be stacked during transportation and storage. Do not double stack.



Package to be transported and stored with care (fragile! Should not suffer drops or receive impact)

# TECHNICAL SPECIFICATIONS

Dimensions (mm/inches)

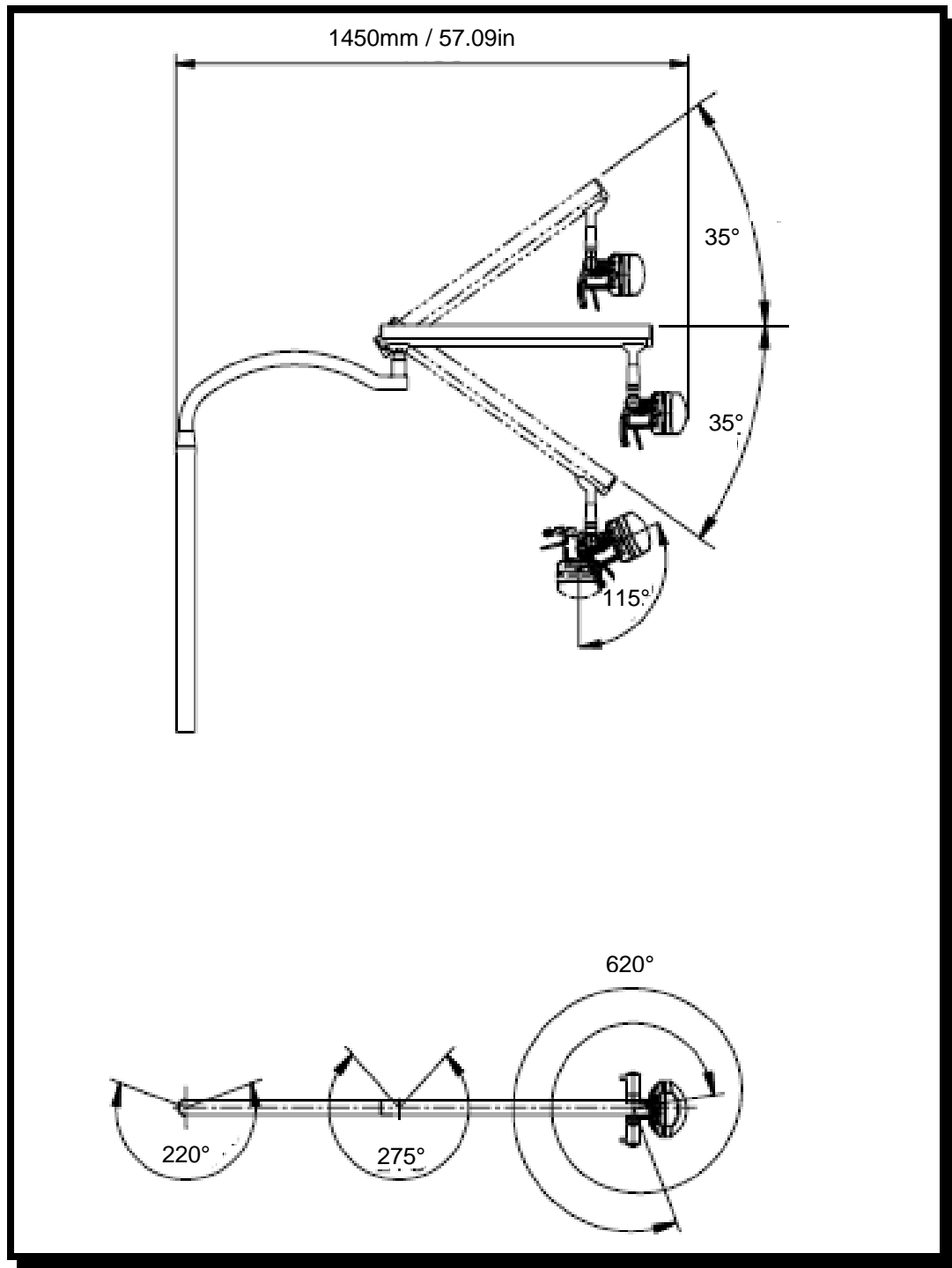

# OPERATION

## Activating the Light

To turn the light on or off, press button (07).

To change the light's intensity use switch (06) on the light head.

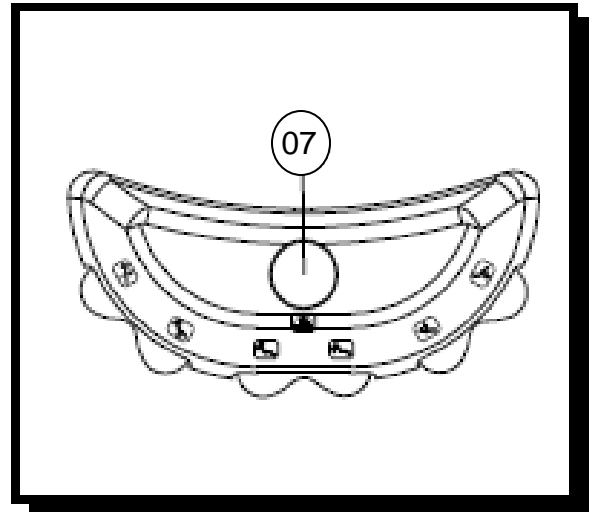

## Head Movement

The handle (02) turns the light vertically and horizontally.

 Light is hot!

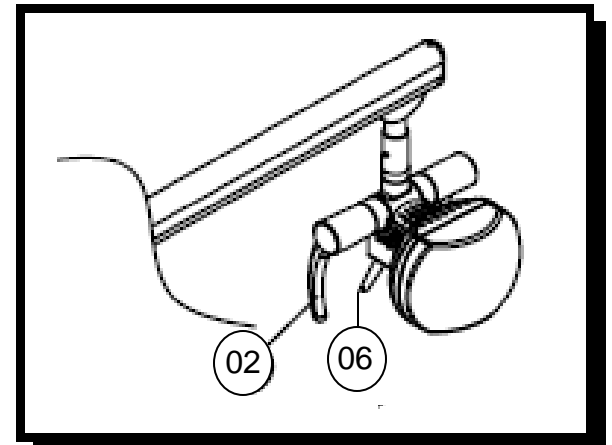

# MAINTENANCE

## Recommendations for the Conservation of Dental Equipment

Your Summit Dental Systems equipment has been designed and developed according to the standards of modern technology. Similar to other kinds of equipment, it requires special care, which is many times neglected due to several reasons and circumstances.

Therefore, here are some important reminders for your daily routine. Try to follow these simple rules, which will save you a lot of time and will avoid unnecessary expenses once they become a part of your working procedures.

### Precautions

-  Certify the correct voltage when you plug in your equipment to the electricity.
- Install your equipment in a proper place protected by solar rays and humidity.
- Whenever equipment is not in use, turn off the main switch.

# MAINTENANCE

## Changing the Bulb

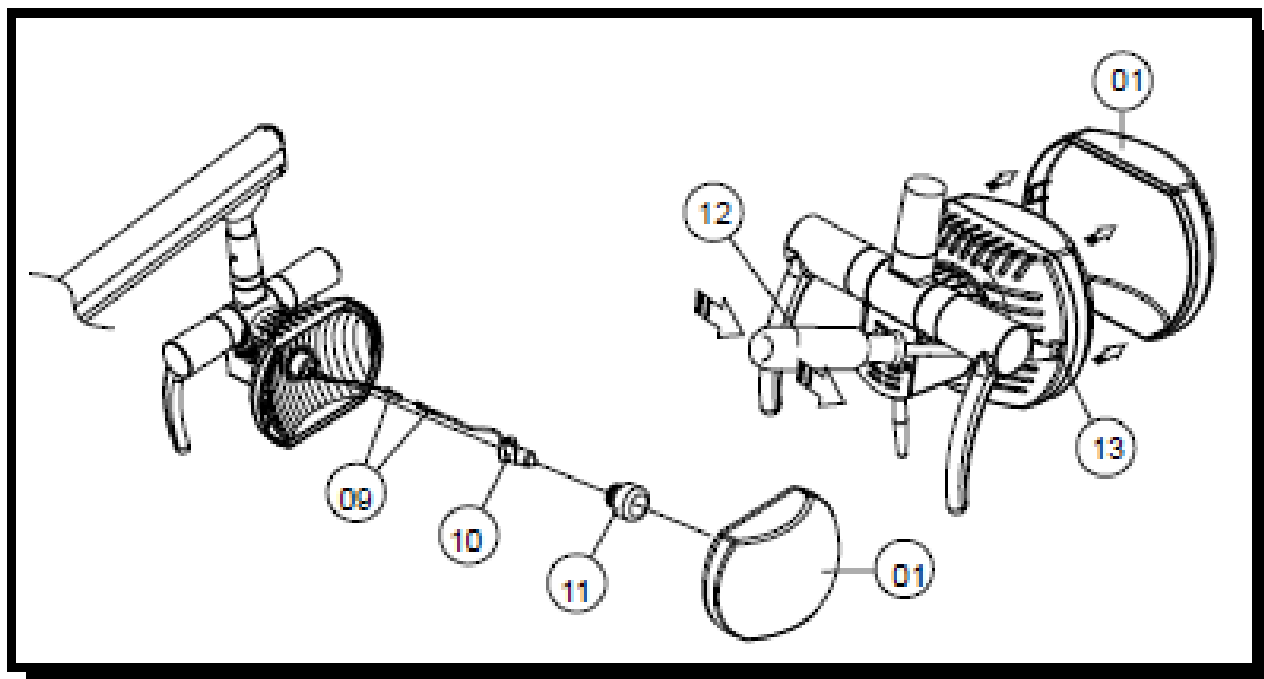

- Turn off the chair's main switch or the circuit breaker;
- Make sure the light is cold;
- Through a key cleft (12) remove the cover (01) engaging the friction latch gently (13) in the direction of the arrow (right).
- Unscrew counterclockwise in the baffle (11) and pull the bulb (10) carefully until you locate the terminals (09);
- Disconnect the terminals and replace the bulb.

### ATTENTION:

Never touch the lamp bulb with your fingers.  
Wipe the bulb thoroughly with Isopropyl Alcohol before inserting the bulb.

## Cleaning of the Splash Shield

**IMPORTANT:** When cleaning the protective splash shield (01), only flannel or cotton moistened with water should be used. To prevent scratching never use any chemical product for the cleaning of the reflector, because it may cause stains.

# MAINTENANCE

## Cleaning the Equipment

To perform the cleaning of your equipment, we recommend using the product "BactSpray" or any other with similar characteristics:

**Active ingredient:** Benzalkonium Chloride (Quaternary Ammonium Tri-)  
Sun at 50 %..... 0.329%

**Composition of the product:** BUTYLGLYCOL, Decyl Poliglicose, Sodium Benzoate, Nitrite Sodium, Essence, Propane / Butane Deodorized, demineralized water.

For further information on cleaning procedures, see the instructions by the product's manufacturer.



### ATTENTION:

- In order to eliminate safety hazards or equipment damage, we recommend that while cleaning there is no penetration of liquid inside the equipment.
- The use of other chemical products with solvent-based or sodium hypochlorite for cleaning are not recommended as they may damage the equipment.

## TROUBLESHOOTING

Problem	Probable Cause	Solution
<ul style="list-style-type: none"> <li>- Light is not working</li> </ul>	<ul style="list-style-type: none"> <li>- Power is cut</li> <li>- Chair fuse is blown</li> <li>- Bulb is burn out</li> </ul>	<ul style="list-style-type: none"> <li>- Wait until power is back</li> <li>- Replace fuse(s)</li> <li>- Replace bulb</li> </ul>

### ATTENTION:

Any other problem that could happen with this equipment should only be repaired by an authorized Summit Dental Systems technician.

Any misuse, negligence or maintenance not performed by an authorized Summit Dental Systems technician will result in the loss of the warranty.

# INSTALLATION

## Attention:

All operations of electrical connections must be performed with the chair turned off the electrical network.



## Position for Mounting

(1) Connect the chair to the electrical network, turn on the main switch, and activate on the foot control the pedal that lifts the seat, lifting it to the maximum height. Activate the backrest's control button until the an intermediary position is reached (halfway between the lowest and highest point the backrest can be raised or lowered to). Turn off the main switch and disconnect the plug from the electrical network

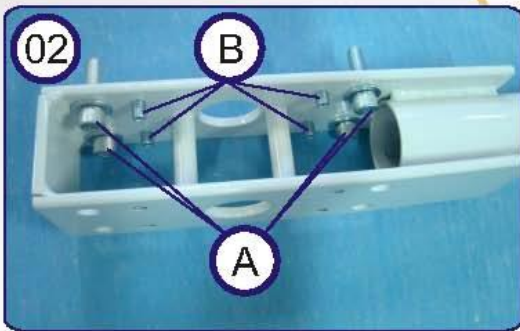

(2) Prepare the support post by fixing the screws:  
(A) Fixation: 04 allen with flat washers and nuts  
(B) Leveling: allen 04 ¼ " without head



(3) Mount the support post positioning it on the chair

# INSTALLATION



(04) Regulate the level of the post using both methods (C) and (D) with the use of 4 1/4" allen screws without heads.



(05) After leveling, adequately tighten the 4 screws (A). Use an allen key type 5/16" and a wrench 9/16".



(06) Mount the back plate and secure it through the 4 hex bolts with flat washers. Use a wrench 7/16".

# INSTALLATION



(07) Mount the frame to the seat, setting it through the 2 hex bolts with flat washers and nuts. Use two fixed wrenches 9/16".



(08) Using an allen key type 1/4" mount the chair's fixed arm to the chair base.

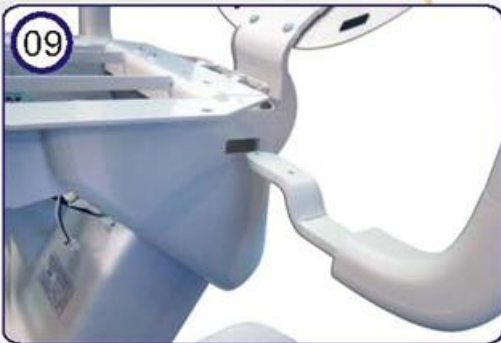

(09 and 10) After mounting the arm, attach it with 2 allen screws. Use an allen key type 3/16".

To mount the second arm, follow the same instructions



# INSTALLATION



Remove the light from the packaging.  
(11) Mount the arms



(12) Pass the electrical wires through the hole in the post while guiding the wires so that they do not touch the arm's limiter while in motion.



(13) Fit light into post



(14) Remove the fixation screw from the front cover of the housing. Use a Philips screwdriver.



(15) Remove the 2 back Philips screws (left and right side). Use a Philips screwdriver. Remove the cover.

# INSTALLATION

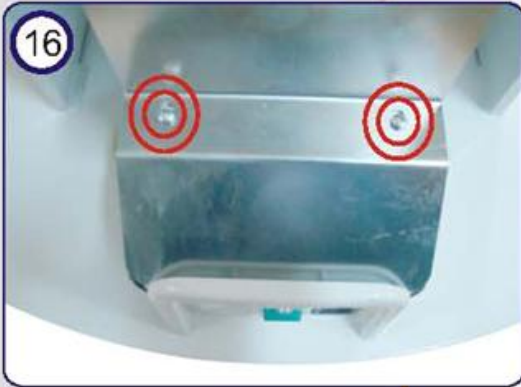

(16) Remove the screws of the protective layer of the PCB cover.



(17) Fish the light's electrical wire through the opening in the seat.

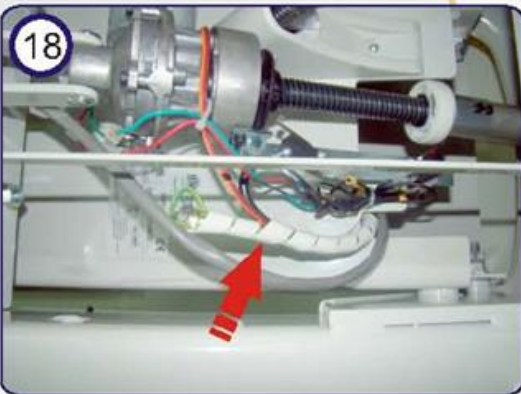

(18) Remove the spiral to release the grounded wire.



(19) Pass the grounded wire through the same opening in the seat or through the hole located on the lower part of the light post. Use a Philips screwdriver.

(20) Roll up the spiral around the wires along with the light's electrical wire.

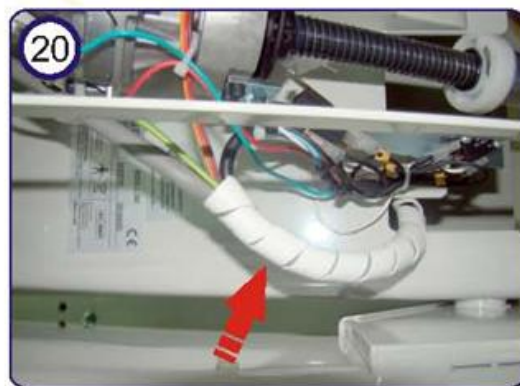

# INSTALLATION



(21) Pass the light's electrical wire over the cover of the actuator.



(22) On the front and back part of the chair, pass the light's wire through the supporting passage.

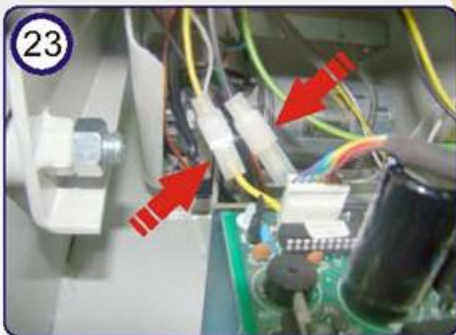

(23) Connect the black and yellow wires located behind the transformer.

(24) Connect the white wire to the electronic board.

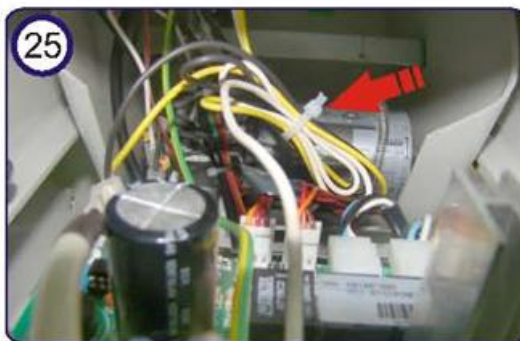

(25) Strap the wires with a plastic tie strap.

# INSTALLATION

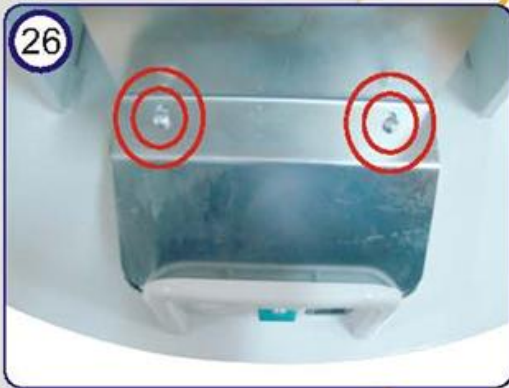

(26) Replace the PCB's protective cover and the screws. Use a Philips screwdriver.



(27) Replace the housing cover and the screws (left and right side). Use a Philips screwdriver.



(28) Attach the screw onto the front part of the cover. Use a Philips screwdriver.

# WARRANTY

Summit Dental Systems (SDS) warrants its products against defects in materials or workmanship from the date of shipment to the Buyer as follows:

**Summit Dental Systems (SDS) Equipment:**

Chairs, Delivery Units, Cuspidors, Lights  
 Control Block Diaphragm (part of Delivery Unit)  
 All Upholstery, Stools, all Plastic Covers, and Cabinets

**Warranty Period:**

5 Years  
 Lifetime  
 1 Year

Summit Dental Systems' sole obligation under the warranty is to provide parts for repair, or at its option, to provide a replacement product (excluding all labor and shipping fees). "In any action, BUYER'S remedies are limited to the warranty described above. BUYER shall not be permitted to claim lost profits, reliance, special, incidental, or consequential damages in any proceedings." The warranty does not cover damage from improper installation or maintenance, accident or misuse. The warranty does not cover damage resulting from the use of cleaning disinfecting or sterilization chemicals and processes. Failure to follow instructions provided in Summit Dental Systems' Operation and Installation Manuals (Owner's Guides) may void the warranty. In the event Warranty service must be performed to correct any defect, only an authorized Summit Dental System dealer may perform any and all warranty repairs. Any repairs by unauthorized dealers, technicians, or repairmen may void the warranty.

- In the case of a defective warranty item, a copy of the replacement invoice, model and serial number of the product under which it was replaced, and a description of symptoms of the defect must be returned with the part within 30 days of the replacement invoice date to Summit Dental Systems, 6277 NW 28<sup>th</sup> Way, Ft. Lauderdale, FL 33309, USA, in order to receive credit. Any and all expenses for freight, labor to perform warranty service, and purchase of spare parts are the responsibility of the buyer. Any fraudulent claims made may void the warranty. Any additional warranty that may be provided by an authorized Summit Dental Systems dealer is the sole responsibility of said dealer.
- SDS reserves the right to make changes or improvements on any products without being required to modify existing equipment in a like manner.

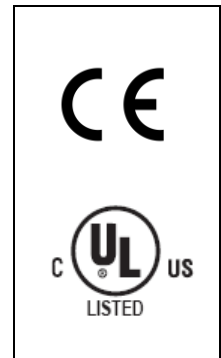

**Please complete and retain for your records the following Information:**

In case of warranty part replacement/repair or when ordering a part, please call your authorized Summit Dental Systems dealer and have the following information available:

<b>Owners' Name:</b>	<b>Phone #:</b>
<b>Model #:</b>	<b>SDS Serial #:</b>
<b>Dealer:</b>	<b>Phone:</b>
	<b>Purchase Date:</b>

## FINAL CONSIDERATIONS

---

The most important aspect related to equipment care is that concerning spare parts. To guarantee the maximum life span of your equipment, use only **original Summit Dental Systems spare parts**. They are sure to follow the technical specifications and standards required by Summit Dental Systems.

We must also point out to you our network of authorized dealers. Only dealers within this network will be able to keep your equipment constantly new for they count on technical assistants who have been trained and possess specific tools for the correct maintenance of your equipment.

Questions and Information: Summit Dental Systems Call Center 1-800-275-3368.

**Manufacturer/ Distributor:**



MT Promedt Consulting GmbH  
Altenhofstrasse 80  
D-66386 St. Ingbert, Germany

